

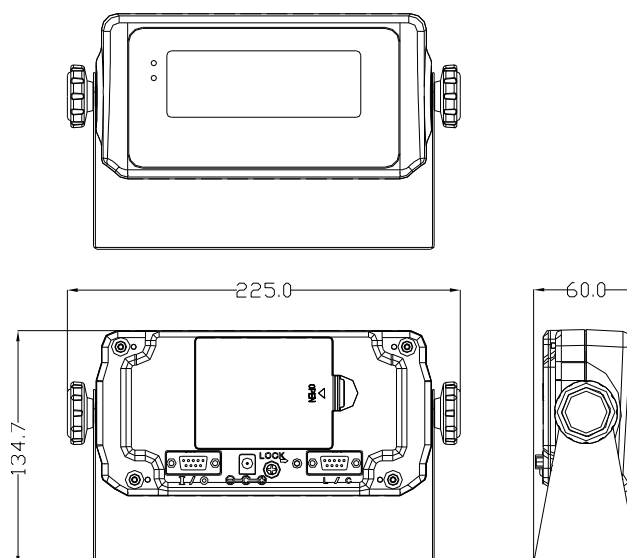

529-e

Weighing Indicator, Type FM25

- For exact Indication of Weight at simple weighing operations
- For Industrial Applications, Resolution up to 20.000 divisions
- Internal Functions:
 - > Animal Livestock Weighing
 - > Dual Range Scale
- ABS housing, frontside IP54, with swivel bracket for desk mount
- 25.4 mm LCD-digits with LED backlight
- 7 Keys for Operation, Calibration and Input of Parameters
- Input for max. 4 Load Cells, each 350 Ω ; Input Signals: -0.2 to +3.2 mV/V
- Serial Interface RS232 for printer or PC
- Power Supply:
 - > 9 V DC 1000 mA (external PSU for 120/250 V, 50–60 Hz)
 - > 6 V DC (built-in Ni-MH battery (1800 mA / 1 h) (operation time without re-charging up to 30 hours)
- Operating Temperature: 0 °C to +40 °C



All dimensions in mm.